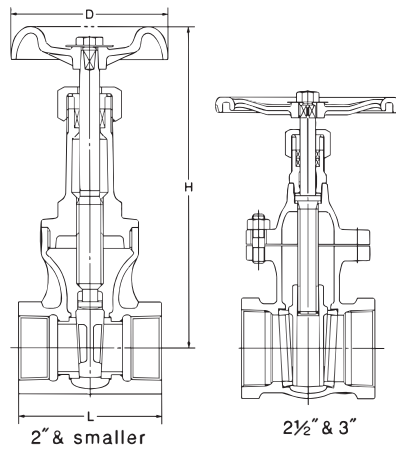

**Fig. 10SM**



**Class JIS 10K**



**Dimensions**

size	mm inch	15	20	25	32	40	50	65	80	mm
		1/2	3/4	1	1 1/4	1 1/2	2	2 1/2	3	
L		60	70	75	85	95	105	130	145	
H (OPEN)		150	171	198	233	274	318	253	294	
D		60	70	80	90	100	115	180	180	

120°C Static water.....1.37MPa(14kgf/cm<sup>2</sup>)  
 220°C Steam, air,gas,oil.....0.98MPa(10kgf/cm<sup>2</sup>)

- Use for lubricating or hydraulic oil is acceptable. Contact KITZ Corporation for technical advice, if valves are used as heat transfer media.
- Employment of copper disc prohibits use of this valve for ammonia or amine chemicals.

**Test pressure**

Body	2.06MPa (21kgf/cm <sup>2</sup> ) [hydrostatic]
Seat	1.51MPa (15.4kgf/cm <sup>2</sup> ) [hydrostatic] 0.59MPa (6kgf/cm <sup>2</sup> ) [air]

**Materials**

Parts	JIS material
Body	FCD-S
Bonnet	FCD-S
Stem	SUS 403
Disc	CAC 406
Body seat ring	SUS 403(1/2" & 3" : SCS1)
Gland	SUS 403
Gland packing	Non asbestos
Packing nut	FCD 400
Handwheel	FCD 450(2 1/2" & 3" : FCD400)
Wheel nut	SS 400
Gasket	Non asbestos
Name plate	A1050P

**Fig. 10SMBOF**



**Class JIS 10K**

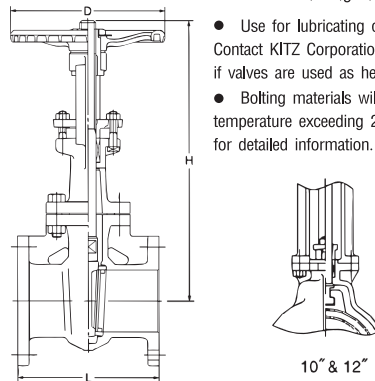

**Dimensions**

size	mm inch	40	50	65	80	100	125	150	200	250	300	mm
		1 1/2	2	2 1/2	3	4	5	6	8	10	12	
L		165	178	190	203	229	254	267	292	330	356	
H (OPEN)		300	352	410	479	566	667	779	993	1181	1404	
D		160	200	200	250	250	300	300	350	400	450	

120°C Static water.....1.37MPa(14kgf/cm<sup>2</sup>)  
 220°C Steam, air,gas,oil.....1.18MPa(12kgf/cm<sup>2</sup>)  
 300°C Steam, air,gas,oil.....0.98MPa(10kgf/cm<sup>2</sup>)

- Use for lubricating or hydraulic oil is acceptable. Contact KITZ Corporation for technical advice, if valves are used as heat transfer media.
- Bolting materials will be changed for servicing high temperature exceeding 225°C. Contact KITZ Corporation for detailed information.

**Test pressure**

Body	2.06MPa (21kgf/cm <sup>2</sup> ) [hydrostatic]
Seat	1.51MPa (15.4kgf/cm <sup>2</sup> ) [hydrostatic] 0.59MPa (6kgf/cm <sup>2</sup> ) [air]

**Materials**

Parts	JIS material
Body	FCD-S
Bonnet	FCD-S
Stem	SUS 403
Disc	SUS 403 (1/2"-8")
	SFVC2A+13Cr (10")
	SCPH2+13Cr (12")
Body seat ring	SUS 403 (1/2"-3" : SCS1)
Gland	FCD-S
Gland packing	Non asbestos
Handwheel	FCD 400
Wheel nut	SS 400
Bonnet bolt/nut	SS 400
Gland bolt/nut	SS 400
Yoke sleeve	C6782BE (8"-12" : HBSC2)
Yoke(10" & 12")	FCD-S
Gasket	Non asbestos
Name plate	A1050P

Asbestos-free gaskets are optional.